

Development on Automatic Vehicle Speed Control Using Radio Frequency Technology

¹Chidiobi Michael Obinna and ²Emeka Okorie

¹Engineer at Analog to Digital Engineering Nigeria Limited.

²Department of Computer Science, Tansian University Umunya.
Email:analog2digital@yahoo.com

ABSTRACT

Reducing the rate of occurrence of road accidents is a big challenge to traffic officials and road users in various parts of the world. These accidents mainly result from the behavior of the driver in respect to speed control while driving. Most drivers drive vehicles at high speed even in speed limited areas and under undesirable traffic conditions without considering the safety of the public. While it is not practical to monitor all parts of the road throughout the time, it is not also possible for the traffic police to control the drivers with full effect. The advancement in wireless sensor technology has made it possible to develop autonomous in-vehicle systems capable of effectively restricting over speeding in various traffic and road conditions. Thus, in this project, a model was proposed and developed for the control of vehicle speed system using fuzzy logic inference system in conjunction with the radio frequency identification (RFID) technology. The application of the proposed model to various road conditions and speed limits were simulated and observed using Matlab simulink toolbox. The results from the simulation showed an improvement in the vehicle speed control by over 51.4% compared to a conventional PID based vehicle speed control system.

Keywords: radio frequency, vehicle speed control, transmitter, receiver.

INTRODUCTION

Over speeding is a growing problem in both rural and urban areas just as accidents resulting from it are increasing day by day [1]. Most of these road accidents are caused because the automobiles are driven at high speeds even in the places where sharp turnings and junctions exist [2]. Nigeria and other countries in the world lose a large number of their citizens to many cases of vehicle accidents every year [3]. A report by the Federal Road Safety Commission (FRSC) of Nigeria showed that as much as 32% of all accidents that occurred in the year 2013 were attributed to speed related issues [4]. The Association for Safe International Road Travel [5], reported that about 1.24 million people die and 50 million are injured on the roads of the world every year [6]. Traffic management in some designated areas, improving quality of road infrastructure and safer vehicles are some of the common measures that have been adopted to reduce accidents on the

road. Earlier attempt at controlling the speed of vehicles lead to the development of a wide range of speed control devices, like top speed limiters, automatic speed limiters, on-board monitoring devices and crash recorders [7]. Limiting the top speed of your vehicle is usually done either through engine management systems, or through a device which controls the throttle or the fuel injectors directly. Even though the traffic officials control and monitor drivers' speed in some areas, it not possible to achieve full compliance to road speed limits and a round-the-clock monitoring most times. Thus this project paves way for automatically controlling the speed of vehicles within certain limits in those restricted zones without the interruption of the drivers [8]. This system is applicable for any speed limit which can be set or controlled as per the road's need such as bends, hospital zones, etc. Here the RFID technology was used, with RF

tags and readers attached in the vehicle and at specific points on the roads in the restricted zones. The following objectives were achieved in this project.

- i. A study of the model of a vehicle speed control system

The system model and simulation were done using the MATLAB Simulink toolbox. The implementation of this technology could help avoid accidents due to over speeding and also to enable the public to cross the road without facing any danger from high speed vehicles.

The developed system is significant due to the following reasons:

- The method of tracking and controlling the speed of vehicles using radio frequencies is much easier to implement, economical and also highly effective. While artificial vision based recognition of traffic signals might fail if visibility is poor (insufficient light, difficult weather conditions or blocking of the line of sight by preceding vehicles), RF signals might still be transmitted reliably
- Since such systems have remote and automatic control on a vehicle in a speed restricted zone, it offers real-time, in-vehicle feedback on over-speeding, existing speed limits and possible danger areas for drivers, and requires little

Review of related works

Over the past three decades, different types of technologies have been deployed with a view to controlling the speed of automobiles in order to reduce all cases of accidents on the roads. An early stage development saw [10] patenting an automatic car speed controller which has a driving circuit operated by the difference between the actual car speed and the memorized car speed. The difference signal is then used to operate an electromagnetic clutch. In spite of these efforts, reduction of the number of accidents and mitigation of their consequences still remain a big issue for traffic authorities, vehicle manufacturers, and transport research groups. One

- ii. Characterization of a radio frequency-based speed control system
- iii. The development of a model for RF signal transmitter and receiver
- iv. The design of a vehicle speed limit controller using RFID and fuzzy logic

human presence to function effectively.

- Speed limiting systems using radio frequency could be extremely useful for drivers of electric cars that are too quiet and smooth to feel the speed of the vehicle. Audible alarms and virtual engine sounds produced by the system would let the driver know they are moving above specified speed levels, improving the safety of these vehicles.
- On a general note, speed management systems are great for commercial passenger vehicles as there are sometimes different speed limits for passenger vehicles on certain highways and roads. Voice alerts and audible tips, and sometimes an automatic reduction in speed level, ensure that drivers obey the limits and deliver their passengers safely to their destinations [9].

important development involves the use of advanced driver assistance systems (ADAS) [11] which are acoustic or visual signals produced by the vehicle itself warn the driver of an impending danger and to communicate to the possibility of a collision. These systems are used in some commercial vehicles today, and future trends indicate that higher safety will be achieved by automatic driving controls and a growing number of sensors both on the road infrastructure and the vehicle itself. A common example of driver assistance systems is cruise control (CC), which has the capability of maintaining a constant user preset speed and its evolution, and the adaptive cruise control

(ACC), which adds to CC the capability of keeping a safe distance from the preceding vehicle. Further improvements in speed control systems saw the development of curve Warning systems (CWS), which use a combination of global positioning systems (GPS) and digital maps obtained from a Geographical Information System (GIS), to assess threat levels for a driver approaching a curve and to quickly warn the driver of danger. Likewise, the intelligent speed assistance (ISA) systems warn the driver when the vehicle's velocity is inappropriate [12,13]. These systems use the GPS in the vehicle in combination with a digital road map containing information about the driver's speed limit. A memorized digital map included in the system enables the speed

These factors may not always exist in developing countries like Nigeria. Furthermore, [10] reported a system that uses the Radio Frequency Identification (RFID) to identify traffic signals on the road and also facilitate infrastructure to vehicle communication. This elaborate system not only controls the speed of vehicle and shows its location using the global positioning system (GPS) but is also Research efforts did not stop at systems using radio frequencies to control the speed of vehicles.

In the work of [12], the authors proposed an automatic speed control system based on colour strips for highway road and the roads where the speed control within limit is required. The methodology explains that various colour strips are marked on highway roads or the roads where the speed control within limit is required and vehicle will have a colour sensor attached which will recognize the colour marked on the highway road and accordingly maintain the vehicles speed in that particular limit. According to [8], a vehicle speed monitor/ controller with a dashboard display was developed. Their work presented a new design to control the speed of the automobiles at remote places for a fixed time. The project comprised two separate units: Zone status transmitter unit and Electronic Display and Control unit. Once the road-sign signal is received from the RF transmitters in the zones, the vehicle's

limit of the location to be determined so that the driver can be properly advised to stay within this prescribed speed limit. However, these systems, though are very useful, are complex and ineffective in cases of unexpected road conditions (like roadwork, road diversions, accidents, etc.), which would need the use of dynamically generated digital maps. Besides they need a direct line of sight with the orbital satellites to work, and a detailed construction of the digital maps of all the roads in a country where it is deployed as well as the availability and maintenance of good roads [7]. The GPS may not work in areas where there are tall buildings and trees which could obstruct the line of sight signal from the satellites in the orbit.

capable of avoiding vehicle to road infrastructure collisions. Other systems that are based on RFID and RF transmitter- receiver pairs are reported in [11]. These systems require the installations of an extensive road infrastructure in the form of roadside beacons.

Electronic Display Controller Unit warns the driver to reduce the speed to the required limit for the zone. It waits and reduces the speed of the vehicle automatically if the driver fails to respond. Results of the simulation showed that if the system is adopted it can effectively reduce the number of road accidents caused by drivers losing control of the vehicle at speed breakers or by driver's negligence towards traffic signals. A novel adaptive fuzzy sliding automatic speed controller with variable boundary layer for intelligent vehicles has been proposed by [11] in their work. The control gains and the boundary layer thicknesses of the sliding mode speed controller are adaptively tuned by fuzzy logic simultaneously. Additionally, the stability of the proposed closed-loop automatic speed control system is guaranteed by the Lyapunov theory, and the switching criterion between the

throttle and brake actuators is introduced. The performance of the proposed control scheme was evaluated by simulation and experimental tests, and the results showed that the proposed scheme can achieve good speed tracking performance for automobiles. Many problems still exist in spite of the technological developments in systems that control the speed of vehicles.

Research methodology

The system developed in this work uses RFID tags which give the reference speed to the vehicle's ECU (Electronic control unit). The actual speed of the vehicle is

measured using a sensor and is given as another input to the ECU. Figure 1,0 shows a block diagram of the ECU unit

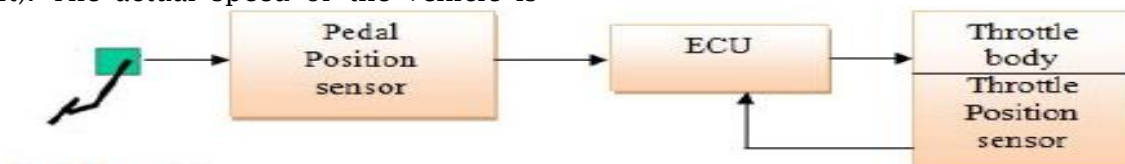

Fig 1.0 Block diagram of the ECU in a vehicle [9]

The main advantage of using a number of interconnected ECU in a vehicle is that they give scalability and functionality to the control operations. Automotive electronic devices not only replace mechanical systems, they also help in integrating other systems. The RFID reader (receiver) and ECU components are located within the vehicle whereas the RFID tag (transmitter) is connected to speed limit signs on roads in the restricted zones. The three main components that make up an RFID transceiver system communicate via radio signals that carry data either unidirectional or bidirectional [5]. The transmitters are programmed to send the coded signals continuously with certain delay in between. Whenever the vehicles enter into these zones their receivers will receive this code from the RFID tags. The

The entire system was modelled and simulated in MATALAB.

The block diagram of the proposed design of automatic vehicle speed control is given in figure 1.2. The various levels of speed controls are activated when a signal transmitted by an RFID tag on the road infrastructure is received by the reader in an oncoming vehicle at a given distance. The signal received from the RFID tags

receiver produces an output which is again an input to the electronic control unit. Using the control algorithm, the ECU analyses and produces an output signal. When the accelerator pedal is moved to increment the speed, the controller calculates the speed that would be reached on the new pedal position. If the speed is greater than the maximum speed limit then it denies the excess speed and gives appropriate signal to the ECU. The ECU warns the driver, to reduce the speed according to the zone, it waits for driver's response and reduces the speed of vehicle automatically to the desired speed level for the zone if the driver fails to heed the warning. A fuzzy logic controller is used to implement the control functions and enhance the system's response to changes in the road conditions.

has coded information regarding the speed limit for that particular area. Using the fuzzy logic control algorithm, this signal is then processed to give a corresponding output to the vehicle ECU which it uses to regulate the speed of the vehicle in line with the RFID tag.

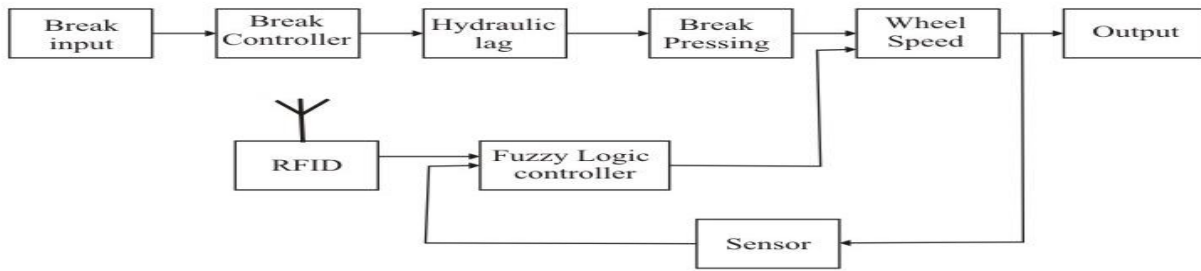

Fig 1.2: Block diagram of a vehicle speed controller with RFID and Fuzzy controller.

In figure 1.2 the input signal is fed into the controller with a first order lag that represents the delay associated with the hydraulic line of the brake system. The output from the hydraulic lag is feed into the break pressure in order to control the rate of brake pressure. The resulting signal is applied to the input of the break

torque. The outputs from the break torque and fuzzy logic control are used to control the vehicle speed. From figure 1.2 it is assumed that the wheel rotates with an initial angular speed that correspond to the vehicle speed before the break is applied as shown in equation 1.0.

$$\omega_v = \frac{V_v}{R_r} \quad 1.0$$

Where

ω_v = wheel angular velocity

V_v =Vehicle linear velocity

R_r = wheel radius

The angular speed is then converted to a linear speed with a linear speed gain of

$2*\pi*\text{wheel radius}$ as shown in the simulink model in figure 1.3

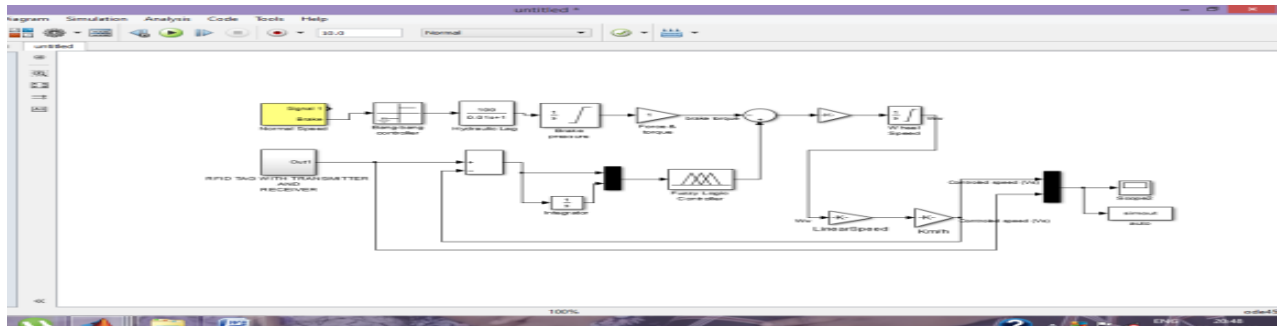

Fig. 1.3: Simulink model of the automatic vehicle speed control with RFID

Model of the Radio frequency identification (RFID) system

The RFID system consist of a transmitter, receiver, wireless channel

and a tag ID as shown in figure 1.4 and figure 3.5

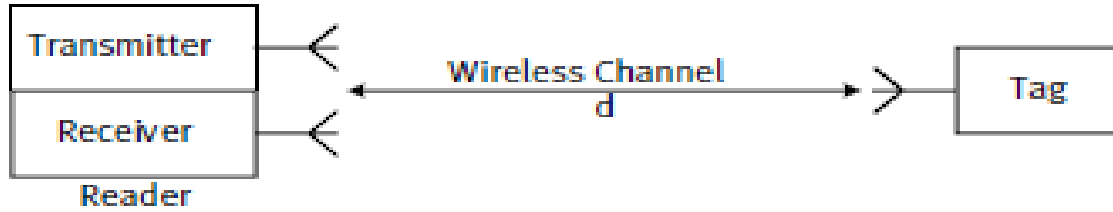

Fig. 1.4: The RFID system block diagram

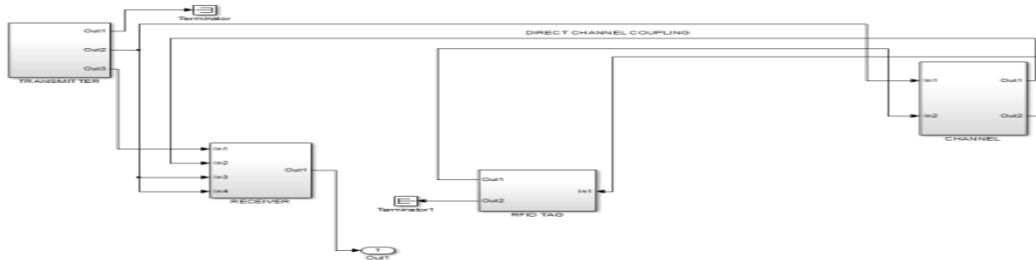

Fig. 1.5: Simulink model of an RFID System

Figure 1.5 is a simulink model showing the various building blocks for the RFID system used in this design. The functions

of these blocks are discussed in the subsections that follow:

RFID Transmitter

The simulink design of the RFID transmitter is given in figure 1.6

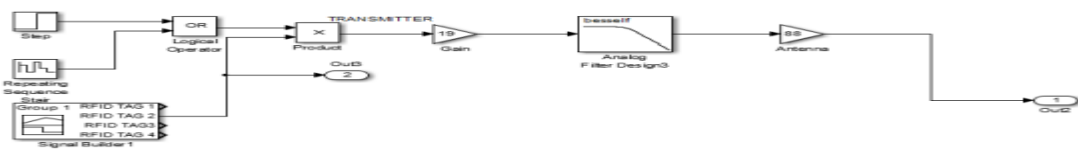

Figure 1.6: Simulink model of an RFID transmitter

The tag code is generated by using a signal builder block. The code is then modulated with a continuous carrier signal. The modulated tag code is used to enable the tag and the continuous carrier signal is used for backscatter of tag ID during return link. Double side band amplitude Modulation (DSB AM) is used as the modulation scheme. The modulated

signal is amplified and band-limited between 860 MHz to 960 MHz using a Fourth order Band pass Bessel's Filter and transmitted through the antenna. The protocol employed for this design is a Manchester coding for forward link and Manchester subcarrier coding for return link.

Channel Model

The wireless channel is modeled by the Friis transmission equation.

The radio propagation model can be expressed as in equation 1.1

$$P_r = P_t \left(\frac{\lambda}{4\pi r_0}\right)^2 \left| G_0^{1/2} \frac{1}{r_0} \exp(-jkr_0) + G_i^{1/2} \sum_{i=1}^n \Gamma(a_i) \frac{1}{r_i} \exp(-jkr_i) \right|^2$$

1.1

When the tag-enabled modulated signal is transmitted, channel noise is incorporated into the signal and consequently degrades the signal. Numerous Channel factors like the Gaussian noise, Multi path Fading etc may be incorporated into the channel model.

Additive Gaussian noise was simulated by a random generation block in figure 1.7. Noise is added in the signal by a Summing block. The signal power also attenuates during its transmission from reader to tag and vice-versa.

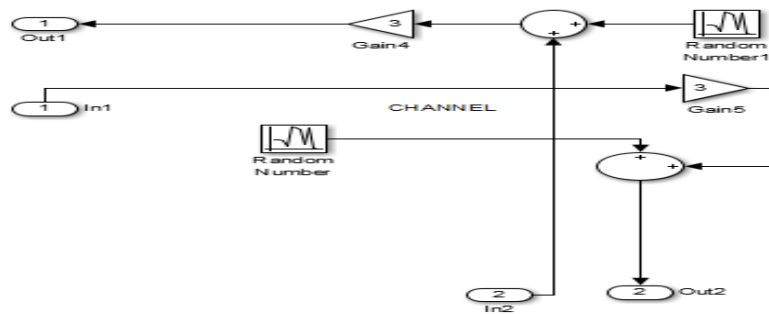

Fig. 1.7: Simulink channel modelling.

RFID Receiver

The simulink model for the RFID receiver is given in figure 1.8

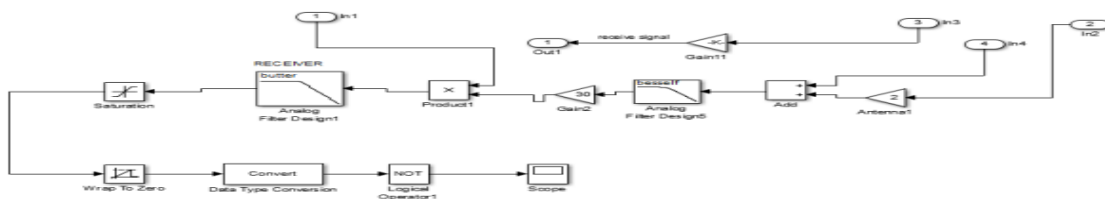

Fig 1.8: Simulink model of the RFID receiver.

The receiver receives the direct signal from the transmitter and the reflected ones from the surrounding environment. However, the strength of the signal reflected from the surrounding

environment is weak and consequently can be neglected. The signal received is sent to the fuzzy logic control for further processing.

RFID Tag

In figure 3.8 the RFID Tag first identifies the code transmitted by the reader and match the code with its own code stored in the memory. If matching occurs, the tag will be enabled and backscatters the

continuous carrier modulated with Tag ID. It does this by changing the reflection coefficient of the tag antenna. The code detection is done by a demodulator with locally generated carrier.

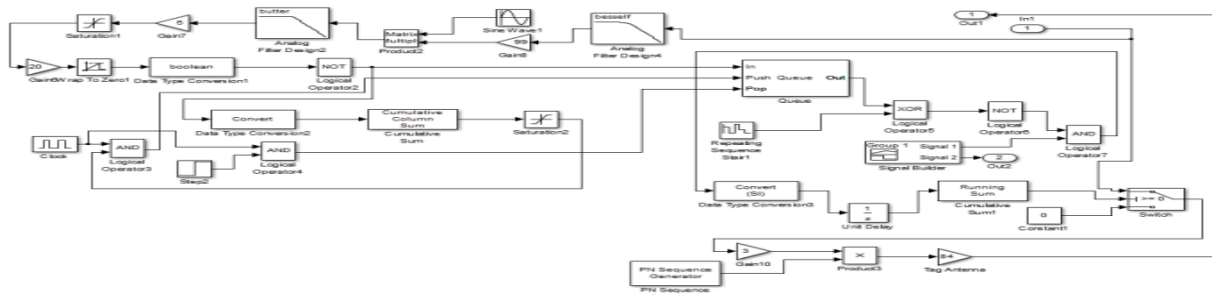

Fig 1.9: Simulink design of an RFID tag 1

Fuzzy logic controller design for the proposed model

Fuzzy logic is an innovative technology to design solutions for multi- parameter and nonlinear control problems. It uses

human experience and experimental results rather than a mathematical model for the definition of a control strategy.

RESULTS AND DISCUSSION

An automatic vehicle speed controller was modelled and simulated using the fuzzy logic tool box and the PID controller tool box in MATLAB. The controller was designed for vehicle speed control on an RFID tagged road. Simulation of the proposed system was conducted in MATLAB and the results of various traffic

conditions in which the RFID tags were modelled for the control of the vehicle speed were obtained. These results were then compared with the results from a conventional PID controller modelled and used for the same purpose. This comparison helped to ascertain the performance of the proposed model.

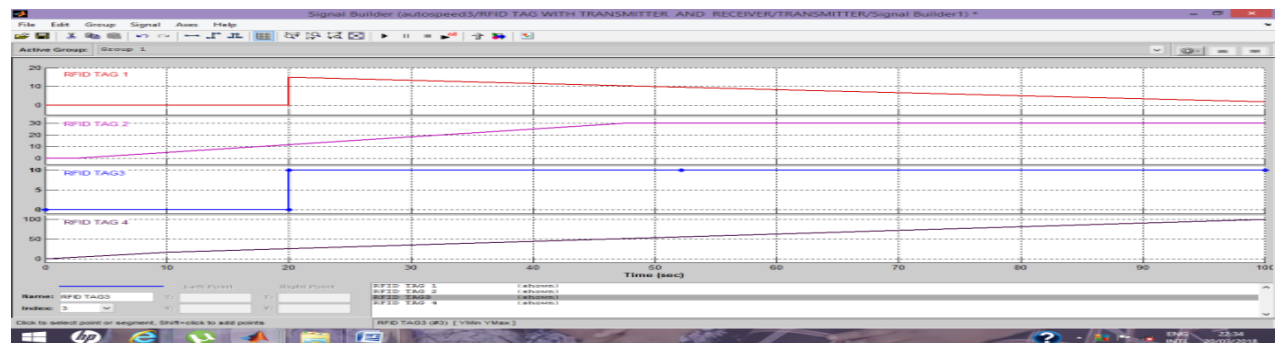

Fig 1.10: RFID tag for various traffic conditions.

For the model it was assumed that the maximum allowable speed for the road is 15km/sec. As soon as a vehicle enters this road, the RFID receiver in the vehicle speed control system picks this speed limit. Once the vehicle speed reaches 15km/sec, the automatic speed controller

takes over the speed control from the driver and ensures that the vehicle speed is kept constant at 15km/sec even if the driver keeps matching the accelerator. From figure 1.11, the graph of the vehicle speed for the two control systems, i.e. fuzzy logic and PID controller, against

time was plotted. The black line represents the graph for the operation of the fuzzy logic controller while the blue line represents the PID controller. For the black line it could be noticed that the speed of the vehicle increased uniformly for the fuzzy controller until it reached 15k/sec. At 15km/sec, the black line remained constant immediately due to the action of the fuzzy logic controller. However, for the blue line which represented the PID controller action, it will be noticed that while the fuzzy logic controller has already responded and kept

the speed constant at 15km/sec within a short time of 26 seconds, the PID controller has not capped up the speed at the designated limit. It however too much longer time, over 100 seconds, as can be seen from the graph for the PID controller to limit the speed at the designated maximum of 15km/sec. The PID model shows a gradual increase in speed but the response level to the RFID Tag signal was low. A 50% improvement on the proposed model as compare to the PID model was obtained.

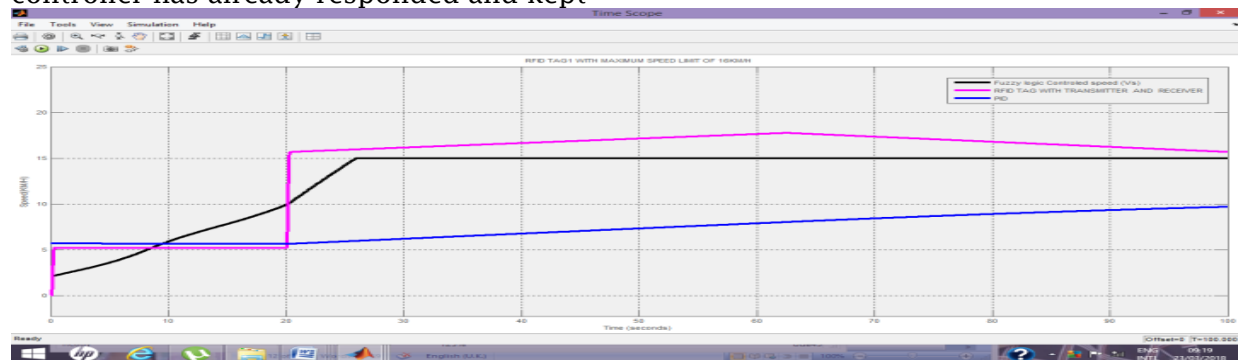

Fig 1.11 :RFID Tag 1 with maximum speed limit of 16km/h

i) Traffic condition of RFID Tag 2 (speed limit: 36km/h)

A signal for a speed limit of 30 km/h received by the controller was simulated and the result obtained is given in figure 1.12. The proposed design maintained a steady increase in speed at 3 seconds to 35 seconds as depicted by the RFID Tag2 and after which a constant speed limit of 30km/h was maintained at 35seconds to

100seconds. When the system traffic increased from 0 - 32km/h, the PID model maintained a slow speed increase while the proposed design model maintained a steady response to the RFID tag traffic. This steady state is as a result of the adaptive nature of the fuzzy logic controller.

The proposed model shows an increase of 200% performance when compared with the PID model.

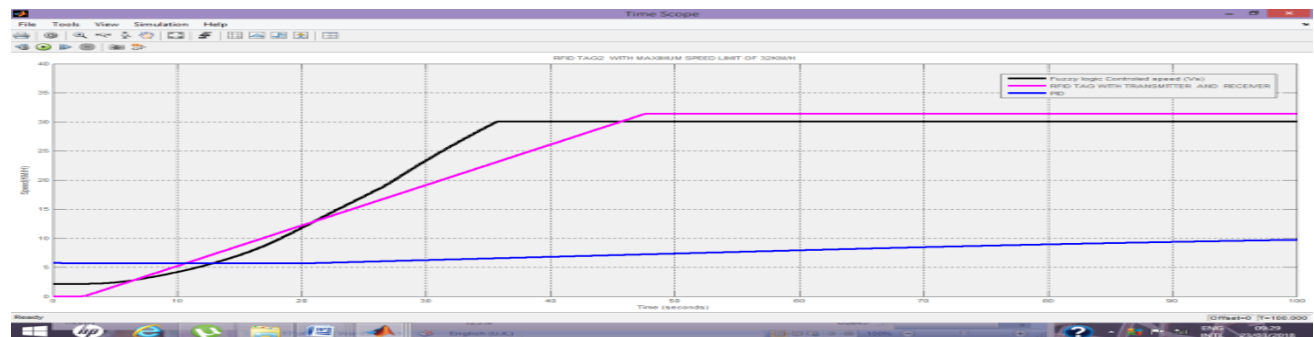

Fig 1.12: RFID Tag 2 with maximum speed limit of 32km/h

ii) Traffic condition of RFID Tag3 (speed limit: 11km/h)

The results obtained for a speed limit of 11 km/h is shown in figure 1.13.

The proposed design maintained a steady increase in speed from 9.8km/h while the RFID Tag maintained a constant speed at 5km/h before an increase in speed to 11km/h. The changes observed were minimal since the proposed model maintained that steady speed. However a constant speed of 9.8km/h was maintained by the fuzzy logic controller

at 20 seconds to 100second. The PID model on the other hand maintained a steady speed of 4km/h (10km/h-6km/h) at 20 seconds to 100 seconds, thereby violating the traffic rule of a constant maximum speed of 12km/h. The proposed model adapted better than the PID model as seen in figure 1.13

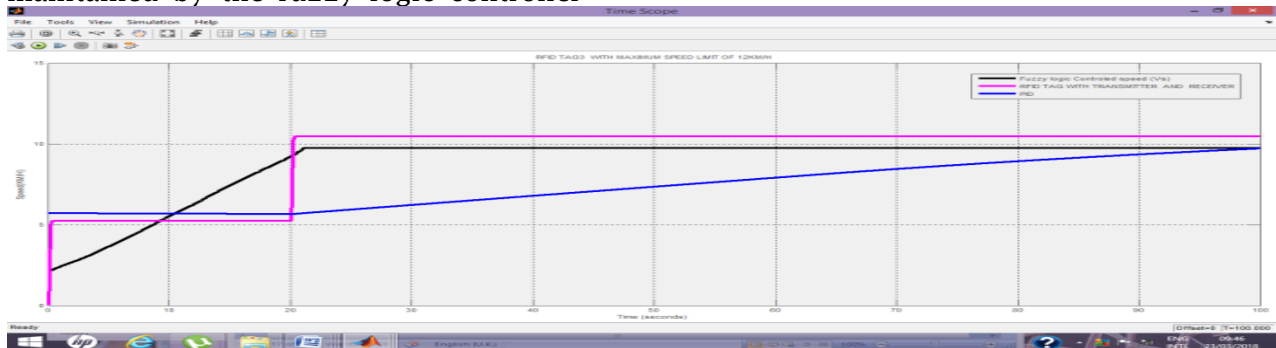

Fig 1.13: RFID Tag 3 with maximum speed limit of 11km/h

iii) Traffic condition of RFID Tag4 (speed limit: 90km/h)

The RFID Tag 4 simulated as shown in figure 4.6 represents a traffic condition where no speed limit is applied. In the

proposed mode a speed limit of 90km/h was used for the design.

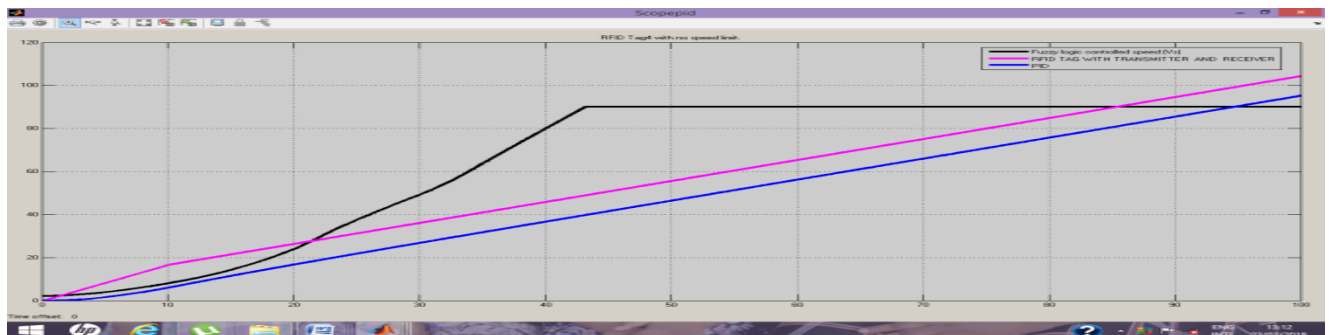

Fig 1.14: RFID Tag 4 with no maximum speed limit

From the results of figure 4.6 the proposed model provides a better control when compared to the PID model. At about 42 seconds to 100 seconds the proposed model maintained a constant

speed of 90km/h and ensured that the speed did not exceed 90km/h irrespective of an increase in the throttle position or availability of any other traffic conditions.

CONCLUSION AND RECOMMENDATION

The advancement in wireless sensor technology shows a great promise in the

designing of an intelligent transport system (ITS) due to its flexibility and cost

effectiveness for deployment. A fuzzy logic model and a PID model for the automatic control of vehicle speed using radio frequency identification were developed. Issues resulting from the use of this proposed model were summarized while possible directions for further research in this area are discussed in this chapter. The results from the simulation of these models showed a great improvement in the ability to keep the speed of the vehicle within certain limits under various traffic conditions. The proposed model greatly outperformed a model that is based on the PID control techniques by over 51.4%. Further improvements to the proposed models for

the automatic control of vehicle speed using RFID system are possible, and could be the subject of further research. The following are some recommendations made:

1. A more intelligent model can be developed by using adaptive neuro fuzzy inference system (ANFIS) that will adapt faster to any changes in traffic conditions. The distance before the vehicle respond to the RFID tag signal can be further investigated to ensure a fast response and an adequate distance is maintained before implementing control on the vehicle.

REFERENCES

1. Atlas RFID solution (2015), <http://rfid.atlasrfidstore.com/hs-fs/hub/300870/file-252314647-pdf/Content/basics-of-an-rfid-system-atlasrfidstore.pdf>
2. Akihiko, T., Iwaoka, T., Yamaguchi, Y. & Danzaki, T. (1990), "Automatic Car Speed Controller with Detection of Abnormality of the Electromagnetic Clutch", Available: <http://www.patents.com/us-5014201.html>.
3. ASIRT, Association for Safe International Road Travel, (2013) <http://www.asirt.org/home.aspx>.
4. Carsten, O. & Tate, F. (2015), "Intelligent Speed Adaptation: The Best Collision Avoidance System?", Proceedings of the 17th Conference on the Enhanced Safety of Vehicles, Netherlands. [Online] Available: <http://tinyurl.com/26cfod>
5. Enokela David & Agbo O. , (2015), "Development of a Microcontroller Based Car Speed Controller Jonathan". Innovative Systems Design and Engineering www.iiste.org ISSN 2222-1727 (Paper) ISSN 2222-2871 (Online) Vol.6, No.6,
6. Kameswari, U.J., Satwik, M., Lokesh, A. & Reddy, G.V. (2011), "A Design Model for Automatic Vehicle Speed Controller", International Journal of Computer Applications, 35, 19-24.
7. Madhu, Adhauya, R., Singh, S., Sambhavi, & Chauhan, A. (2014), "An Advanced Robotic Car for Accidental Preventions", International Journal of Engineering Research and Management Technology, 1, 263-267.
8. Omidiji, A. & Ibitoye, S. (2010), "Crime and Road Crashes Prevention in Public Transportation System in Nigeria: the Case Study of Kwara, Kogi and Ekiti States", 24th ARRB Conference- Building on 50 years of Road and Transport Research, Melbourne, Australia.
9. Federal Road Safety Corps, Federal Republic of Nigeria Annual Report (2013), "Road Crash Statistics", <http://frsc.gov.ng/2013%FRSC%20Annual%20Report.pdf>
10. Paine, M., Paine, D., Griffiths, M. & Germanos, G. (2015), "In-Vehicle Intelligent Speed Advisory Systems", [Online] Available: <http://www.nrd.nhsta.dot.gov/pdf/nrd-01/esv/esv20/07-0247-w-pdf>

- Signals”, *Sensors*, 10, 5872-5887. [Online] Available: www.mdpi.com/journal/sensors
11. Saivignesh H, Mohamed Shimil M, Nagaraj M, Dr.Sharmila B, Nagarajapandian M. (2016), RF Based Automatic Vehicle Speed Limiter by Controlling Throttle Valve, *International Journal of Innovative Research in Science, Engineering and Technology*, pp 230-229.
12. Telaprolu, M.K, Sarma,V.V, Ratankanth, E.K., Rao, S.N., Banda,V., (2009) “ Vehicular Electronics and safety (ICVES), IEEE international conference Pune (2009).
13. Susy d’Hont, (2002), “The cutting edge of RFID Technology and Applications for manufacturing and Distribution”, Texas Instrument TIRIS.